



# QUICK HANGER GANCIO CON MOLLA

## Product description:

The bracket is used for a quick mounting of drywall steel profiles BA 50 or BS 50 into a solid horizontal construction of the building. It is produced by compression molding of rolled galvanized metal sheet with thickness of 1.00 mm and single spring clip which is pressed and locked into the hanger. The installation is done by rotating the bracket into the profile and subsequent hanging on the suspension wire which allows a quick and easy leveling of the construction.



## Range of usage:

The product is used for suspended ceiling construction created from metal profiles in the buildings.

## Characteristics:

<b>Material</b>	Rolled sheet DX51
<b>Coating</b>	Zinc – min Z100 (EN 10327)
<b>Thickness</b>	1.00 mm (EN 10143)
<b>Reaction to fire</b>	Class A1(EN 14195)
<b>Durability</b>	Class B
<b>Hazardous substance</b>	NPD

## Product variability:

Code	Name	Load	Pack	Weight
BXSU381	Quick hanger bracket BA 50/27 - rotary	0,40 kN	100 pcs	0,0336 kg
BXSU382	Quick hanger bracket BS 50/27 - rotary	0.40 kN	100 pcs	0,0336 kg

Real weight may vary in range of +/-5% according to ČSN EN10143

## Mounting:

First we anchor the suspension wire into a solid structure of the building. By pressing hanger spring together we line up the holes and slide hanger onto the wire in desired height. Profile is then mounted by rotating the hangers along the axis of the wire and locking it into the profile.

## Packaging:

The connectors are packed by 100 pcs in carton box. Every dimension is labeled with identification tag.

## Recommended storage:

The product is required to store in dry and temperate environment in order to prevent condensation on the surface of the product and damage to the packaging.

## Technical drawing:

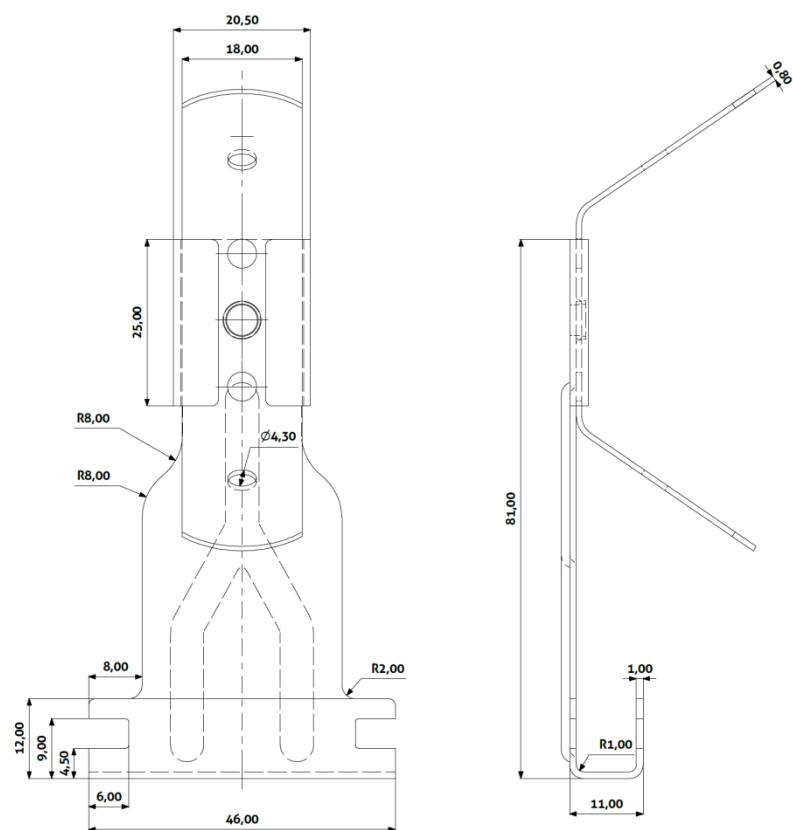

**BA**

**BS**

